

PROJECT NAME: _____

LOCATION: _____

SPECIFIER ITEM NO. _____ **QTY:** _____

COMPONENT HARDWARE PART NO. _____

Component Hardware® Fan Access Panel
FG99-0005



The affordable solution to fire code requirements for cleaning and inspection of fan blades.

Rugged Weatherproof Construction

- Heavy duty, HNBR rubber bonded to closed cell foam
- Corrosion resistant zinc plated hardware

Easy Installation & Operation

- Fits most commercial fan bases
- Space saving design
- Installs in less than 30 minutes from the outside of the fan
- Retaining spring arms hold panel in place
- Eyebolt facilitates removal
- Provides 4" access opening for inspection and cleaning of fan blades

Code Compliant

- In compliance with requirements of NFPA Standard 96.8.5.3.1

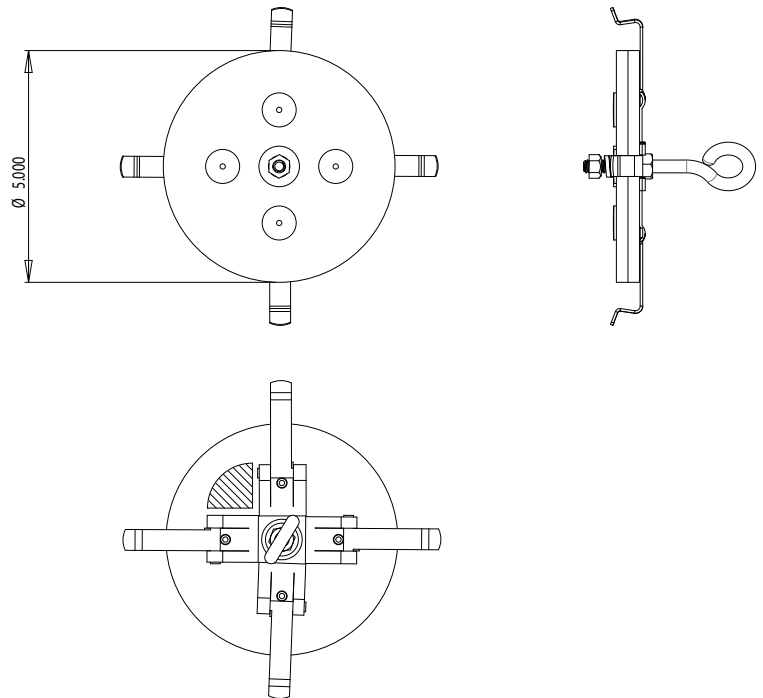

Dimensions shown in inches (mm) are for reference only and are subject to change.

Approximate shipping weight - 1 lb
Lifetime warranty for service life of fan